

**Programmable crystal controlled CTCSS tone encoder kit**

It can encode the 47 CTCSS tones listed below and generates a sign wave. The tone is selected by the combination of jumpers in 6 positions, and the module is only 30 x 49mm in size. It's powered by 7.5 to 16V DC and draws only a few mA.

There is an encode enable input that connects to the radio's PTT line (active low), and the tone select inputs are constantly read so you could change tone with a switch if desired. You can tie the encode enable input to ground for continuous encode.

Output level is fairly flat from 67 to 118Hz at approx. 2V p-p and then falls gradually to approx. 600mV p-p at 254Hz, most radio's require less CTCSS input level at higher frequencies so this is ideal.

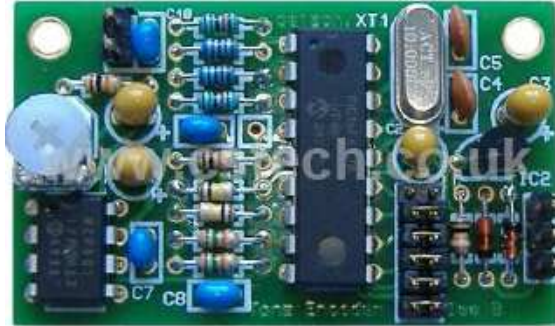

**Circuit diagram on the last page.**

Parts list:-

- R1, 2, 11 10K
- R9, 10 15K
- R4, 5 62K 1%
- R7, 8 100K
- R3, 6 150K 1%
- VR1 10K variable
- C1, 2, 3, 9 1uF tant.
- C4, 5 33pf
- C8 47nf (marked 473)
- C6, 7 100nf (marked 104)
- C10 470nf (marked 474)
- D1, 2 1N4148
- IC1 PIC16F627A programmed with CTCSS code
- IC2 78L05
- IC3 MCP601
- XT1 10MHz crystal
- CN1 2 x 6 pins (supplied as 2 off 2x3)
- CN4 2 pins
- CN5 3 pins

- 1 = +7 to 16V DC
- 2 = 0V or Ground
- 3 =  $\overline{\text{PTT}}$  (encode enable)

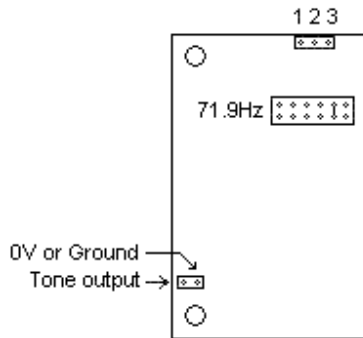

PCB cstech.co.uk Tone Encoder Issue B

Also supplied:-

- Crystal insulator pad
- 5 off 2mm pitch jumpers

**Now includes easy addressing of UK tones.**

This makes the kit compatible with RadCom UK article addressing whilst retaining all 47 tones as usual. See blue tones in tone list below.

When building the kit fit the resistors and diodes first, note that C6 is between R2 and R6 on the PCB although it's ident is under IC1 due to space restrictions. CN3 isn't supplied or fitted.

Observe polarity of the 1uf tant. capacitors and orientation of the IC's and diodes (see picture above).

Fit the 5 supplied jumpers in the following combinations to select the desired tone frequency.

A jumper is fitted to represent a logic zero (0).

000000	118.8	010000	254.1	100000	183.5	110000	110.9
000001	118.8	010001	254.1	100001	179.9	110001	107.2
000010	118.8	010010	250.3	100010	173.8	110010	103.5
000011	118.8	010011	241.8	100011	167.9	110011	100.0
000100	118.8	010100	233.6	100100	162.2	110100	97.4
000101	118.8	010101	229.1	100101	159.8	110101	94.8
000110	118.8	010110	225.7	100110	156.7	110110	91.5
000111	110.9	010111	218.1	100111	151.4	110111	88.5
001000	103.5	011000	210.7	101000	146.2	111000	85.4
001001	100.0	011001	206.5	101001	141.3	111001	82.5
001010	94.8	011010	203.5	101010	136.5	111010	79.7
001011	88.5	011011	199.5	101011	131.8	111011	77.0
001100	82.5	011100	196.6	101100	127.3	111100	74.4
001101	77.0	011101	192.8	101101	123.0	111101	71.9
001110	71.9	011110	189.9	101110	118.8	111110	69.3
001111	67.0	011111	186.2	101111	114.8	111111	67.0

When connecting to a radio transceiver the tone should be fed into the TX modulator after the microphone amplifier/filter/limiter and usually after the TX audio deviation control.

Keep any wiring from a switch to the input(s) short, it is also advisable to fit a 100 ohm resistor in series with each wire at the module end (this limits current into the PIC chips input protection circuits from static).

All parts and the PCB are RoHS compliant and can be soldered with tin/lead or lead free solder.

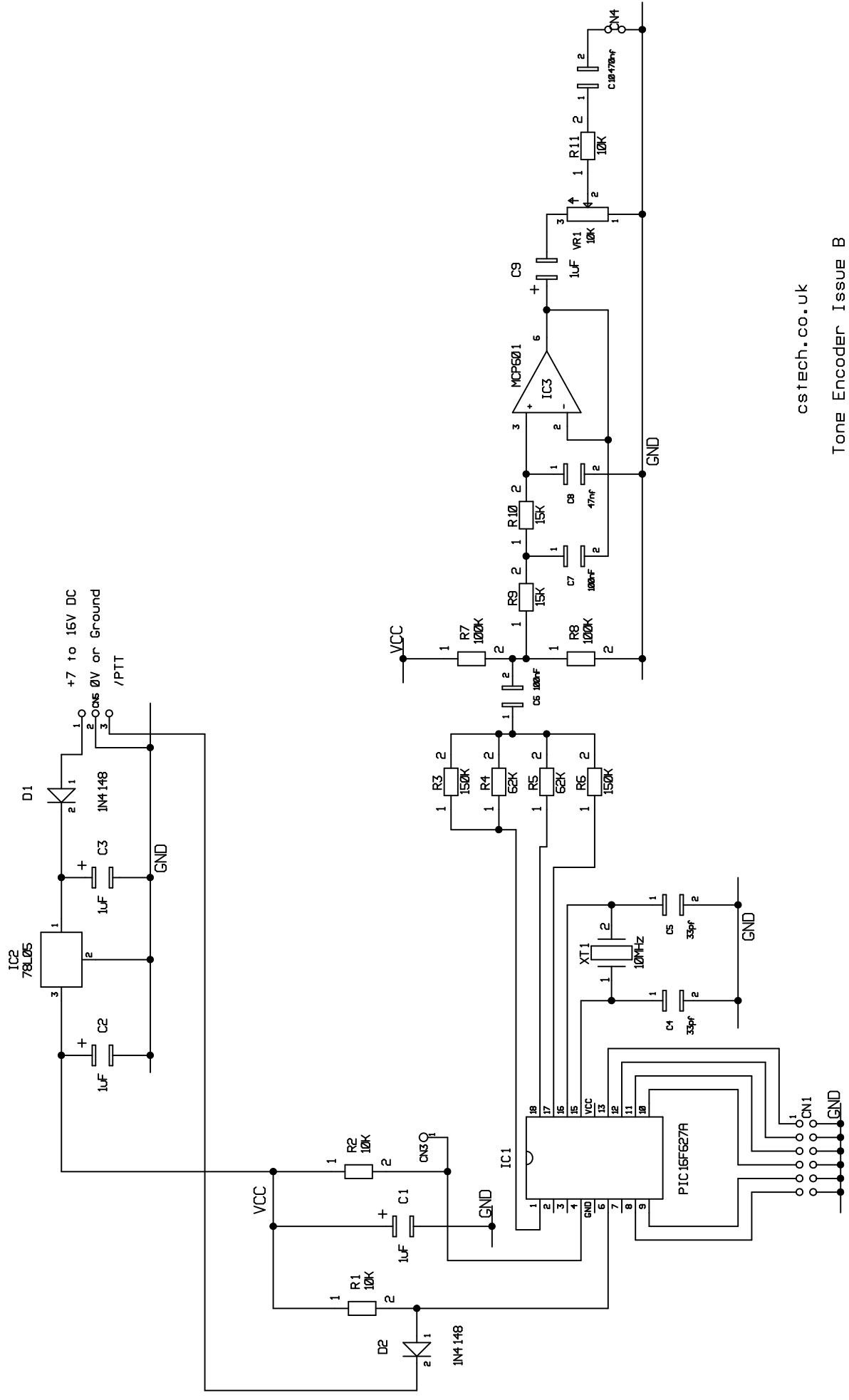

csstech.co.uk

Tone Encoder Issue B