

DTMF detector kit with binary outputs.

Our DTMF detector kit allows the quick implementation of the HT9170 DTMF receiver IC.

Three input configurations are possible, un-balanced audio, balanced audio and microphone.

The 4 binary outputs of the HT9170 together with the data valid (DV) strobe are made available on the 8 pin connector; together with the output enable input (OE) and the power connections. If output enable is not required just link it to the 5V pin.

The kit will work on 3V to 5V DC therefore the kit can also be used with say 3.3V logic.

The PCB is double sided PTH (plated through hole), 38mm x 30.5mm in size and Gold Plated.

All parts shown in the assembled photo are included as well as some extra resistors for alternative input configuration.

The pins can be fitted on the top or on the back of the PCB. Fitting the pins on the back allows fitting the whole assembly onto 0.1" pitch boards.

DTMF Detector Parts List

IC1	HT9170B
XT1	3.579MHz crystal
R1*	4K7
R2, 4	not fitted
R5	wire link
R3*	270K
R6*	1K
R7	330K
C1, 5, 6	100nF (marked 104)
C2	not fitted
C3, 4	22pf
CN1	3 pins
CN2	8 pins

Also supplied:-

DTMF detector PCB Issue A
Crystal insulator pad
2 x 10K resistors for alternate input configuration.



All parts shown in the assembled photo are included.

A pdf data sheet for the HT9170B maybe viewed at:-

cstech.co.uk/ht9170.pdf

Applications include:-

- 1, DTMF detector module for use with our PIC proto boards.
- 2, Simple DTMF decoder (remembers last input).
- 3, DTMF remote control of motors etc. via suitable drivers.

*Note:-

Only fit R6 if using an Electret microphone as input.

Only fit R1 & R3 as 4K7 & 270K for use with a microphone otherwise fit R1 & R3 as 10K or calculate a custom input configuration from HT9170 datasheet.

DTMF Detector application notes follow.

There are 3 input configurations for our DTMF decoder, Electret microphone, un-balance and balanced, the 3 options are shown below in the circuit extracts. The HT9170 DTMF decoder chip has a wide input signal range from approx. 27mV to 775mV, but as it contains an op-amp at it's input and the op-amp gain can be altered using different resistor values, many combinations can be achieved.

Please see notes below:

The Electret microphone input version provides power to a microphone insert via R6 (1K) and using R1 at 4K7 and R3 at 270K to set the decoder chip's input op-amp gain to x57 the sensitivity allows pick-up from a DTMF tone pad at a couple of inches. A speaker phone, two-way radio speaker or the keypad tones from a mobile can be picked up 6 to 12 inches away.

We do not recommend increasing the input gain any higher.

Connect the microphone between pins 1 and 2 (2 = GND).

Resistors are provided in the kit for this option.

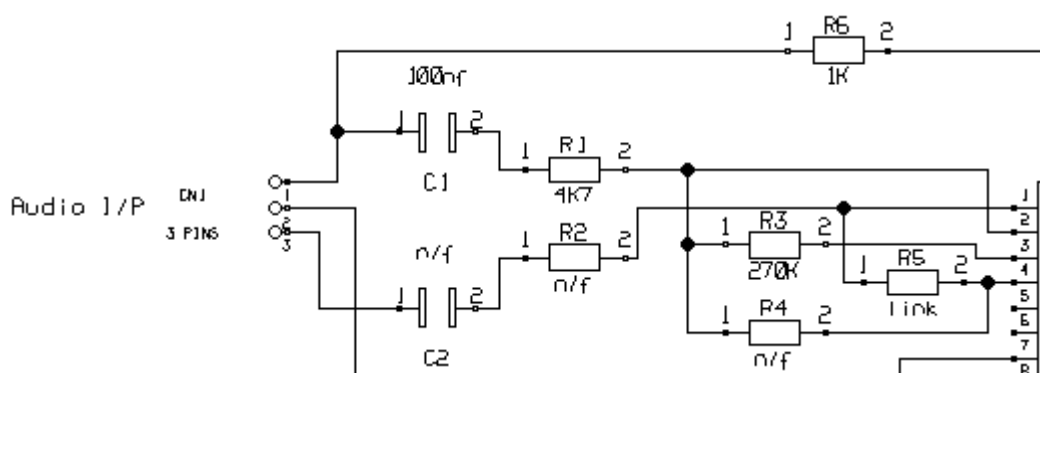

The following example offers an un-balanced audio input, using 10K resistors for R1 and R3 sets the decoder chip's input gain at x1 and gives an input impedance around 10K, R6 is omitted and this configuration can be fed directly from say the Packet modem RX audio output of a Ham radio.

If it is desired to change the input gain then increase R3 for higher gain and decrease R3 for lower gain.

Connect the signal source between pins 1 and 2 (2 = GND).

Resistors are provided in the kit for this option.

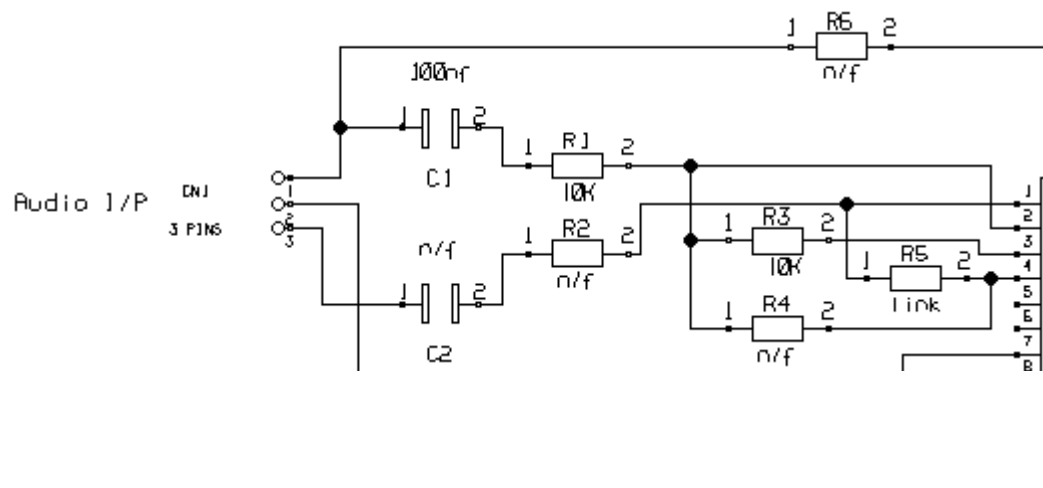

This example of a balanced audio input can be connected to say the earphone audio outputs of a GSM modem, with the values shown the decoder chip's input gain is also x1, however this can be changed as required, see the HT9170 data sheet (cstech.co.uk/ht9170.pdf) for the calculations.

Connect the signal source between pins 1 and 3.

Resistors are NOT supplied in the kit for this option as there are many combinations that could be required.

62K and 36K can be used instead of 60K and 37.5K

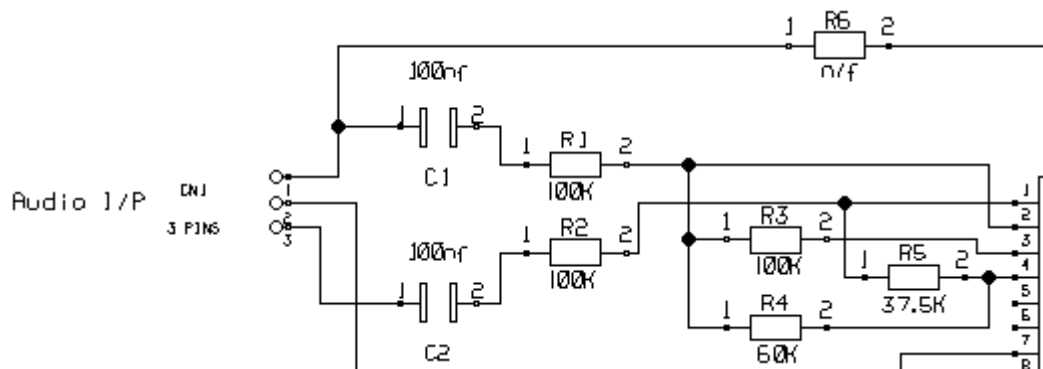

R1 & R3 set input op-amp gain
 C2, R2, R4 & R5 are for balanced input
 R6 = mic power feed option

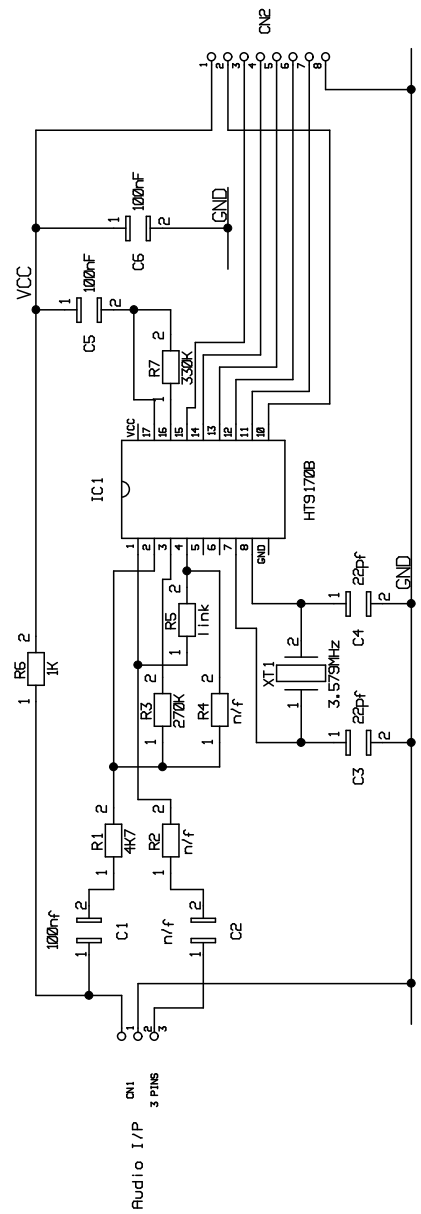

DTMF DETECTOR